

Product data sheet

Sheet No.: 1.605.02 - Rev: A Page 1 of 2

Date: September, 2006

FieldQ

Pneumatic Module Options

Speed Control on FieldQ actuators

Two integrated speed control options are available:

A "One-way" Speed control throttle

This throttle controls only the air flow exhausted from an air chamber and as such limits the speed of the "Opening" or "Closing" stroke (see table "Speed control configuration").

It consists of :

- 1 Nut cover
- 2 Main throttle with set screw
- 3 Spring loaded counter part

B "Two-way" Speed control throttle

This throttle controls the air flow in and out of an air chamber and as such limits the speed of the "Opening" and "Closing" stroke simultaneously (see table "Speed control configuration"). It consists of :

- 1 Nut cover
- 2 Main throttle with set screw.

Note:

With the "Two-Way" speed control it is not possible to set both the stroke cycle times to an equal time.

The actual stroke cycle times depend on the actual load on the actuator during the different strokes.

Speed control on spring return actuators

On spring return actuators only the "central" air chamber is pressurized and vented. Therefore both the "One-Way" or the "Two-Way" throttles must be mounted in the port for the central air chamber port (1). Port (2) must be plugged.

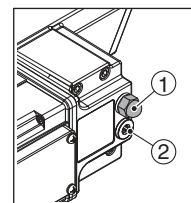

Speed control on double acting actuators

On double acting actuators both the "central-" and "end cap" air chambers are pressurized and vented. Therefore both the "One-Way" and "Two-Way" throttles can be mounted in either ports (1) or (2).

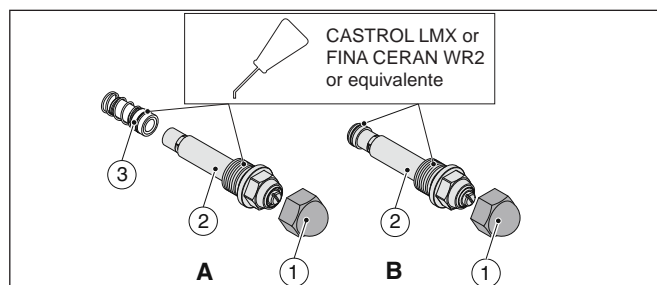
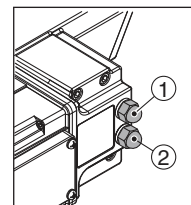

Ps = Pressure supply
Ra = Exhaust
Rb = Exhaust
Pvv = Pilot valve vent
Opv = Over pressure vent

Options:

SC = Speed Control
MC = Manual Control

Double Acting Pneumatic Plan

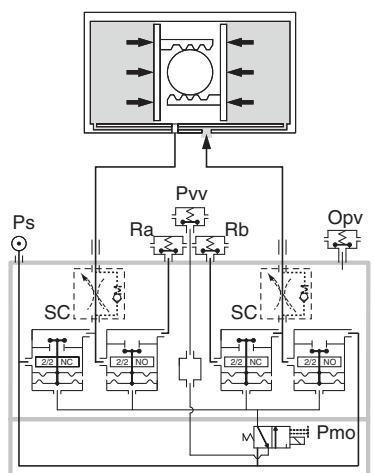

Single Acting (Spring Return) Pneumatic Plan

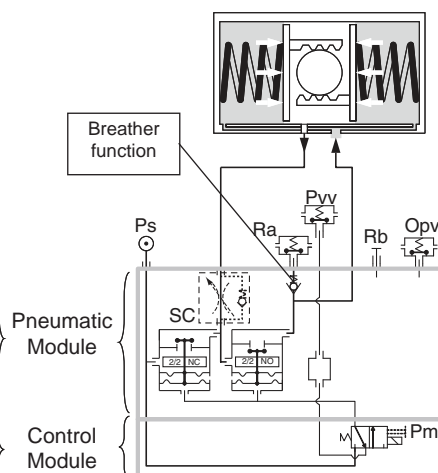

www.FieldQ.com

Copyright © Emerson Process Management. The information in this document is subject to change without notice. Updated data sheets can be obtained from our web site www.Fieldq.com or from your nearest Valve Automation Center:

America's: +1 813 630 2255 (fax +1 630 9449) Europe: +31 74 256 10 10 (fax +31 74 291 09 38) Asia/Pacific: +65 626 24 515 (fax +65 626 80 028)



EMERSON
Process Management

Product data sheet

Sheet No.: 1.605.02 - Rev: A Page 2 of 2

Date: September, 2006

FieldQ

Speed control configuration (see table below)

As indicated, the throttles can be mounted in the port, for the central air chamber(1) or the end cap air chambers(2).

How the actuator functions depends on

- * the action (spring return or double acting)
- * the assembly code (Spring to Close or Spring to Open)
- * which throttle is applied (One way" or "Two way).

Please see the table below to select the required speed control configuration.

"Opening" or "Closing" stroke

- * Whether the speed of the "Opening" or "Closing" stroke is limited, depends on the assembly code of the actuator.

Independently adjusting of the "Opening" or "Closing" stroke speed

- * The speed of the "opening" stroke and "closing" stroke on double acting actuators with 2x "One-Way" throttles can be set independently from each other.

Speed control and actuator sizing

Installing a Speed control option can result in a non-smooth operation of the actuator ("Stick - Slip" behaviour). This behaviour can happen when the actuator size is too small for the application. Selecting an actuator 1 size larger will solve this "Stick - Slip" behaviour.

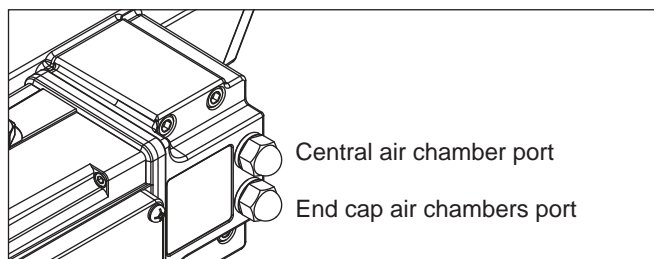

Speed control configuration			Spring return actuators		Double acting actuators	
Option code	Throttle or Plug	in air chamber port	Air Fail to Close (Code CW) Standard"	Air Fail to Open (Code CC)"	(Code CW) Standard	(Code CC)
QP	Plug	Central	No Speed Control	No Speed Control	No Speed Control	No Speed Control
	Plug	End cap				
Q1	"One way SC"	Central	Clock wise stroke (closing)	Counter Clock wise stroke (opening)	Clock wise stroke (closing)	Counter Clock wise stroke (opening)
	Plug	End cap				
Q2	"Two way SC"	Central	Both strokes simultaneously adjustable	Both strokes simultaneously adjustable	Both strokes simultaneously adjustable	Both strokes simultaneously adjustable
	Plug	End cap				
Q3	"One way SC"	Central	Not applicable	Not applicable	Both strokes independently adjustable	Both strokes independently adjustable
	"One way SC"	End cap				
Q4	Plug	Central	Not applicable	Not applicable	Counter Clock wise stroke (opening)	Clock wise stroke (closing)
	"One way SC"	End cap				



www.FieldQ.com

Copyright © Emerson Process Management. The information in this document is subject to change without notice. Updated data sheets can be obtained from our web site www.Fieldq.com or from your nearest Valve Automation Center:

America's: +1 813 630 2255 (fax +1 630 9449) Europe: +31 74 256 10 10 (fax +31 74 291 09 38) Asia/Pacific: +65 626 24 515 (fax +65 626 80 028)



EMERSON
Process Management