

# **BSP UNIVERSAL LOAD CELL**



## **DESCRIPTION:**

The BSP is a stainless steel S-type cell which can be used in tension or compression.

This product is suitable for a wide range of hybrid scales, overhead track scales, belt scales and process weighing applications.

The fully welded construction and water block cable entry ensure, that this product can be used successfully in harsh environments found in the food, chemical and allied process industries.

This product meets the stringent European Weights and Measures requirements through Europe.

## **FEATURES:**

- # Fully welded, stainless steel construction
- # Hermetically sealed, IP66 and IP68
- # Certified to OIML R-60, **3000d**
- # Integrated overload stop (50 6 500 kg)
- # Certified EEx(i) versions are available for use in hazardous areas
- # Current calibration output (SC version) ensures easy and accurate parallel connection of multiple load cells
- # **CAPACITIES: 50 6 5000 kg**

# BSP: SPECIFICATIONS

Standard Capacities (= E <sub>max</sub> )	Kg	50, 125, 250, 500, 1250, 2500, 5000			
Accuracy Class According to OIML R-60			C1	C2	C3
Max. Number of Verification Intervals (n <sub>v</sub> )			1000	2000	3000
Minimum Verification Interval (v <sub>min</sub> )			E <sub>max</sub> /5000	E <sub>max</sub> /10000	E <sub>max</sub> /10000
Minimum Utilisation	%		20	20	30
Accuracy According to Type Designation		CC	C1	C2	C3
Combined Error	%S	#" 0.0500	#" 0.0300	#" 0.0230	#" 0.0200
Non-Repeatability	%S	#" 0.0200	#" 0.0200	#" 0.0100	#" 0.0100
Minimum Dead Load Output Return <sup>1</sup>	%S	#" 0.0500	#" 0.0500	#" 0.0250	#" 0.0167
Creep Error (30 Minutes) <sup>1</sup>	%S	#" 0.0600	#" 0.0490	#" 0.0245	#" 0.0245
Creep Error (20-30 Minutes) <sup>1</sup>	%S	#" 0.0200	#" 0.0105	#" 0.0053	#" 0.0053
Temp. Effect on Min. Dead Load Output	%S/5EC	#" 0.0250	#" 0.0014	#" 0.0070	#" 0.0070
Temp. Effect on Sensitivity	%S/5EC	#" 0.0250	#" 0.0085	#" 0.0060	#" 0.0050
Minimum Dead Load	%E <sub>max</sub>	0			
Maximum Safe Overload	%E <sub>max</sub>	150			
Ultimate Overload	%E <sub>max</sub>	300			
Maximum Safe Sideload	%E <sub>max</sub>	100			
Deflection at E <sub>max</sub>	mm	0.28 max.			
Excitation Voltage	V	5...15			
Maximum Excitation Voltage	V	18			
Rated Output (= S)	mV/V	3 (2 for 2500 and 5000kg)			
Tolerance on Rated Output	mV/V	" 0.03 (" 0.02 for 2500 and 5000kg)			
Zero Balance	%S	#" 1.0			
Input Resistance	Ω	350 " 3.5			
Output Resistance	Ω	350 " 3.5			
Insulation Resistance	MΩ	\$ 5000			
Compensated Temperature Range	EC	-10... + 40			
Operating Temperature Range	EC	-40... + 80			
Storage Temperature Range	EC	-40... + 90			
Element Material (DIN)		Stainless Steel 1.4542			
Sealing (DIN 40.050)		IP66 and IP68			
EEx(I) Certification		EEx ib IIC T6 / EEx ib IIC T4			
SC-Option (Current Calibration)		Standard			

<sup>1</sup> Applies for the temperature range -10 to + 40 EC

**"SC-Option"** The "Rated Output" and the "Output Resistance" are balanced in such a way, that the output current is calibrated within 0.05% of a reference value. This allows an easy parallel connection of load cells.

Accuracy classes C1, C2 and C3 are in agreement with the OIML recommendation R-60. The BSP is certified for tension applications only.

Correct mounting of the load cells is essential to ensure optimum performance. Cable length 10m. Cable screen is not connected to load cell body. Performance may be affected if load cell cables are shortened. Further information is available on request.

## REVERE TRANSDUCERS EUROPE B.V.

Ramshoorn 7  
Postbus 6909, 4802 HX Breda  
The Netherlands  
Tel: (+ 31) 76-5480700  
Fax: (+ 31) 76-5412854

## REVERE TRANSDUCERS INC.

14192 Franklin Ave  
Tustin, CA 92780-7016  
U.S.A.  
Tel: 714.731.1234  
Fax: 714.731.2019

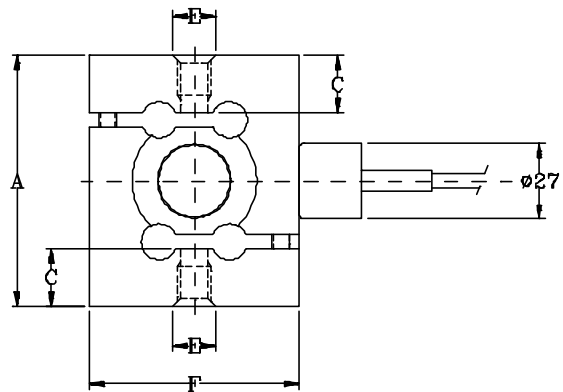
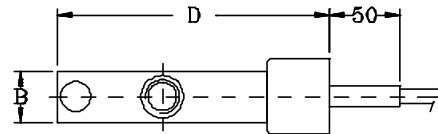

E <sub>max</sub> (kg)	50,125	250	500	1250	2500,5000
A	84.3	88.9	88.9	95.2	120.6
B	23.9	18.0	18.0	24.1	36.6
C thread	12.7	14.0	14.0	14.0	29.2
D	85.7	84.1	96.8	84.1	84.1
E	M8x1.25		M12x1		M24x2
F	63.5	61.9	74.6	61.9	61.9

### REGIONAL OFFICE UK

The Business Centre  
Edward Street, Redditch  
Worcs B97 6 HA, UK  
Tel: (+ 44) 1527-65888  
Fax: (+ 44) 1527-64888

### Wiring:

Excitation +      Green  
Excitation -      Blank  
Output +          White  
Output -          Red  
Shield              Orange

### Attention:

All dimensions: mm.  
Dimension tolerances according to DIN 7168; middle accuracy.  
**Tension applications result in a negative output signal.**  
All specifications subject to change without notice.