

OPTION 3018M

Two Setpoint Alarms (Electro-Mechanical Relays)

This option provides two alarm setpoints with electro-mechanical relays. This option board slots into the upper slot of the panel meter box. The upper terminals are clearly numbered 13-28 to differentiate them from the lower terminals. Both normally open and normally closed contacts are provided with each relay. The relays are rated at 250VAC / 30VDC @ 2A. Visual LED alarm indication is provided on the panel meter front.

- Alarm Set Points are user adjustable from the front panel keys
- Menu adjustable: NO, NC, Hi Lo, delayed turn on timer: Hysteresis.

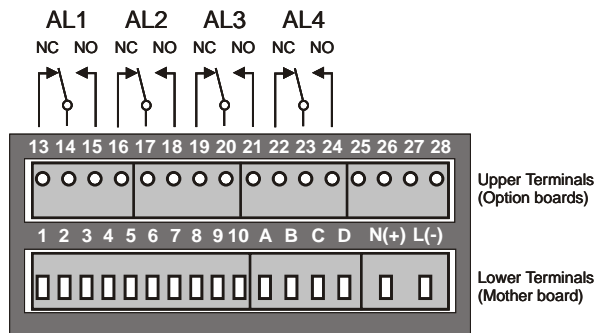

P O Box 418, Honeydew 2040 South Africa
21 Precision Street, KyaSand Randburg.
Telephone: +27 11 462-1920
Telefax: +27 11 462-1958
email: info@instrotech.co.za
web: www.instrotech.co.za