

OPTION 3000

Lineariser (Square Root / Cylinder / Sphere etc)

If fitted, this option will accurately linearise signals for flow applications (square root extraction), s-curve (cylinder applications) and other non-linear signals. The type of linearisation required is specified at time of order and cannot be user selectable. However, the user has the option of toggling the lineariser feature 'ON' or 'OFF'.

Eg "S" CURVE

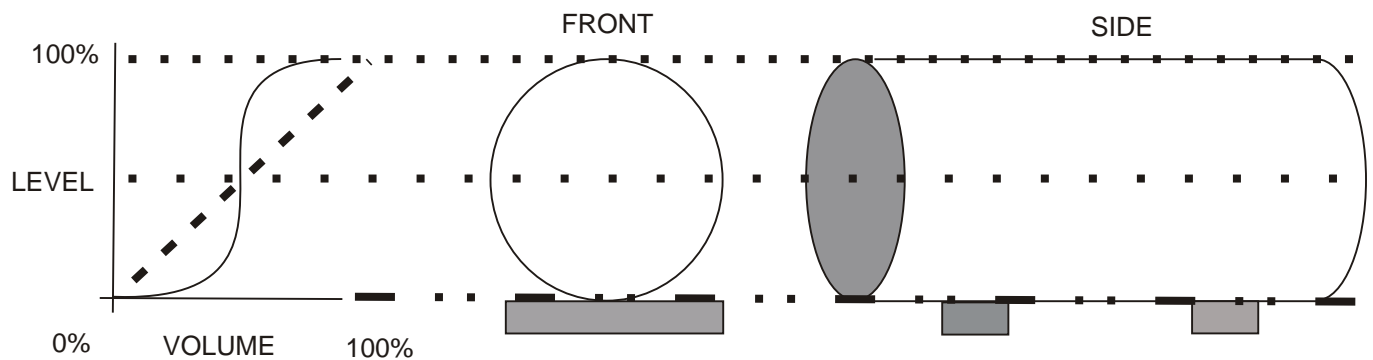

S CURVE EXAMPLE

The input is in level 0..100% while the display is in volume 0..100%.

The lineariser uses one of 32 zero and span ranges to convert the input value to a display value.

The 32 zero and span ranges are programmed at the factory

CUSTOM RANGES

Customer specified curves can be programmed at the factory.



P O Box 418, Honeydew 2040 South Africa

21 Precision Street, Kyaland Randburg.

Telephone: +27 11 462-1920

Telefax: +27 11 462-1958

email: info@instrotech.co.za

web: www.instrotech.co.za



USER PROGRAMMABLE LINEARISER

This option is only available on certain models, check availability.

This lineariser option is used for non-linear input signals.
 A 16 point straight line approximation lineariser is provided.
 The user can enter any number of points from 2 (Linear input signals) to 16.
 The greater the number of points, the greater the accuracy of the linearisation.

DISPLAY CODES EXPLAINED

<code>Lin</code>	Lineariser
<code>on</code>	On
<code>off</code>	Off
<code>PTS</code>	Number of Linearisation Points
<code>02</code> <code>16</code>	Linearisation points
<code>R 01</code>	Actual Display Value
<code>d 01</code>	Linearised Display Value

PROGRAMMING CHART

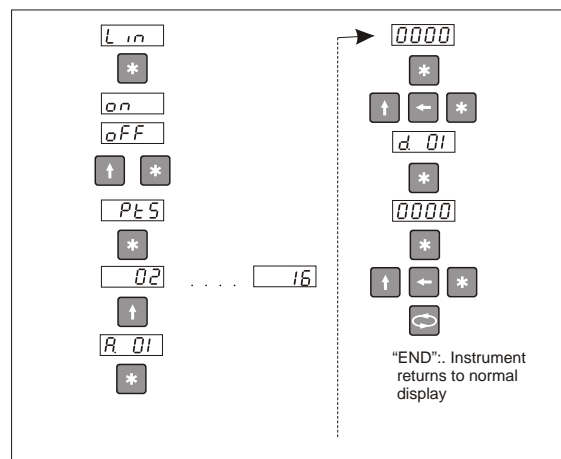

:NOTE:

- If the input signal is beyond the limits of the last actual point entered then the unit will calculate the slope between the last 2 actual values and use this to calculate the required linearised display.
- Do not enter the same actual value for 2 or more points. The unit will compare and select the first sequential point in memory and use this.
- The lineariser points is a mirror image for negative input signals.